

L00774 / L01075 - RECESSED FORMWORK KIT FOR LEFT-SIDE AIR OUTLET

Warnings

- ⚠ This instruction is an integral part of the booklet of the appliance on which the kit is installed. Please consult this booklet for general warnings and fundamental safety rules.
- ⚠ For a rapid and right assembly of the components follow carefully the sequences described in the various sections.
- ⚠ All the operations must be performed by qualified personnel using the required Personal Protective Equipment.
- ⚠ It is necessary, for right functioning of the device, that during the whole installation phase the working space remains clean.
- ⚠ Regularly clear away waste offcuts, debris or dirt.

Installation kit for built-in box for lateral air ventilation SX

L00774 - Recessed formwork for corner installation with left-hand outlet for models .2.0 10 HP, 12 HP

L01075 - Recessed formwork for corner installation with left-hand outlet for models..2.0 15 HP

Use this kit to divert air laterally to a perimeter wall when you intend to place the air conditioner on an interior wall.

The kit consist of:

- a mould for the side air outlet
- cables for electrical connection

⚠ This kit is compatible with the only DC Inverter versions.

Installation arrangement

Preliminary warnings

- ⚠ Ensure that:
 - the support surface is capable of supporting the weight of the appliance
 - the support surface does not affect load-bearing elements of the building, pipes, or electrical lines
- the functionality of load-bearing elements is not compromised
- the support surface is perfectly flat
- there are no obstructions nearby that could compromise the inlet and outlet airflow
- air flow is not directed towards by-standers

Preparation of the wall

To install the unit, prepare the wall for housing the metal casing.

L00774 --2.0 10 HP, 12 HP

- 1. External perimeter wall
- 2. Wall housing mould
- 3. Mould space
- 4. Air outlet hole, 162 Ø

- 5. Air intel hole, 162 Ø
- 6. Hole for wall locking, 8 Ø
- 7. Condensate drain hole, 16 Ø

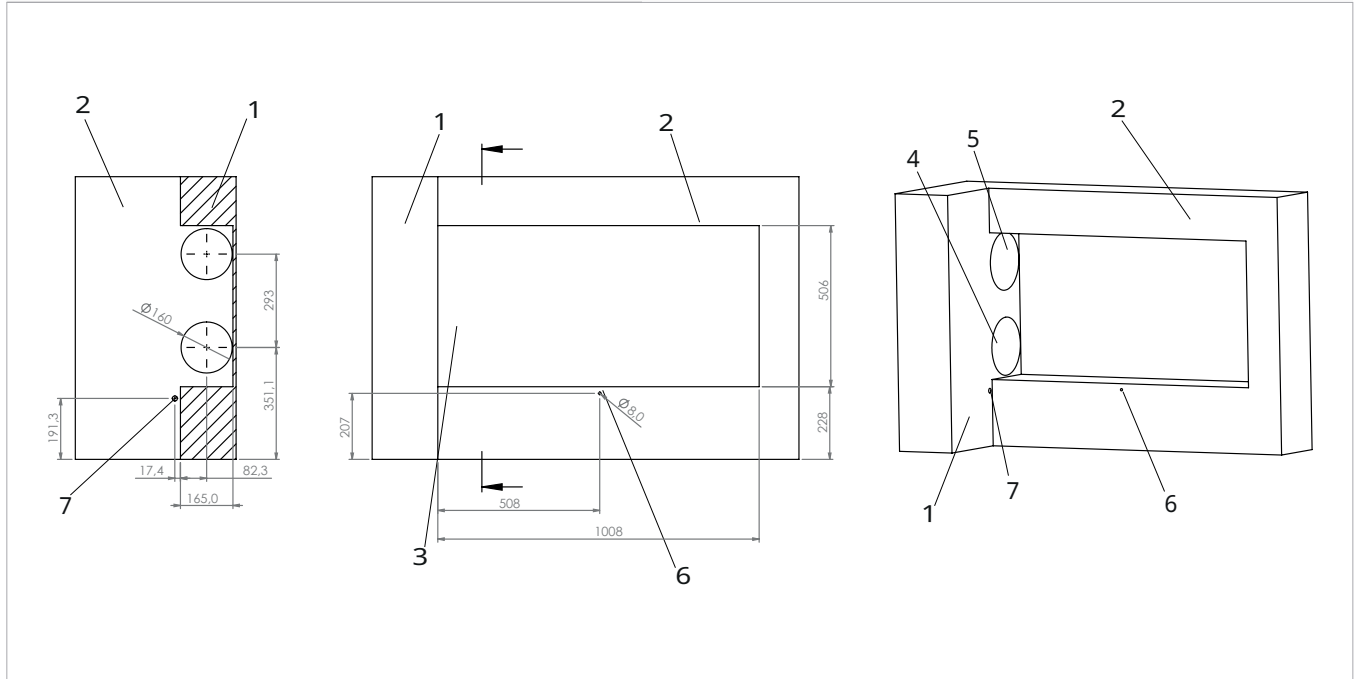

L01075 --2.0 15 HP

- 1. External perimeter wall
- 2. Wall housing mould
- 3. Mould space
- 4. Air outlet hole, 200 Ø

- 5. Air intel hole, 200 Ø
- 6. Hole for wall locking, 8 Ø
- 7. Condensate drain hole, 16 Ø

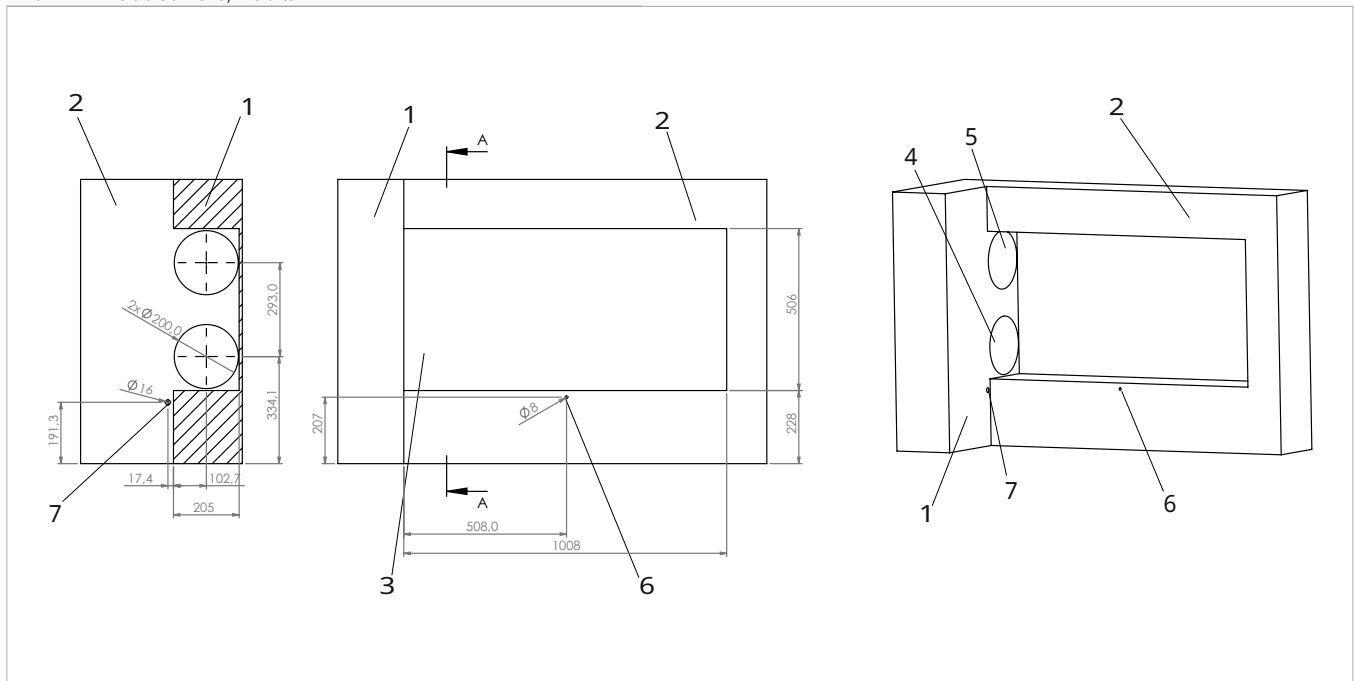

Kit assembly

External grille installation

Before proceeding with the installation of the kit, install the external grilles supplied with the appliance.

⚠ For the installation of the external grilles, refer to the installation manual of the appliance on which the kit is installed.

- 1. External air outlet grill
- 2. Wall inlet pipes (2pz)
- 3. External grill component
- 4. External air intake grill

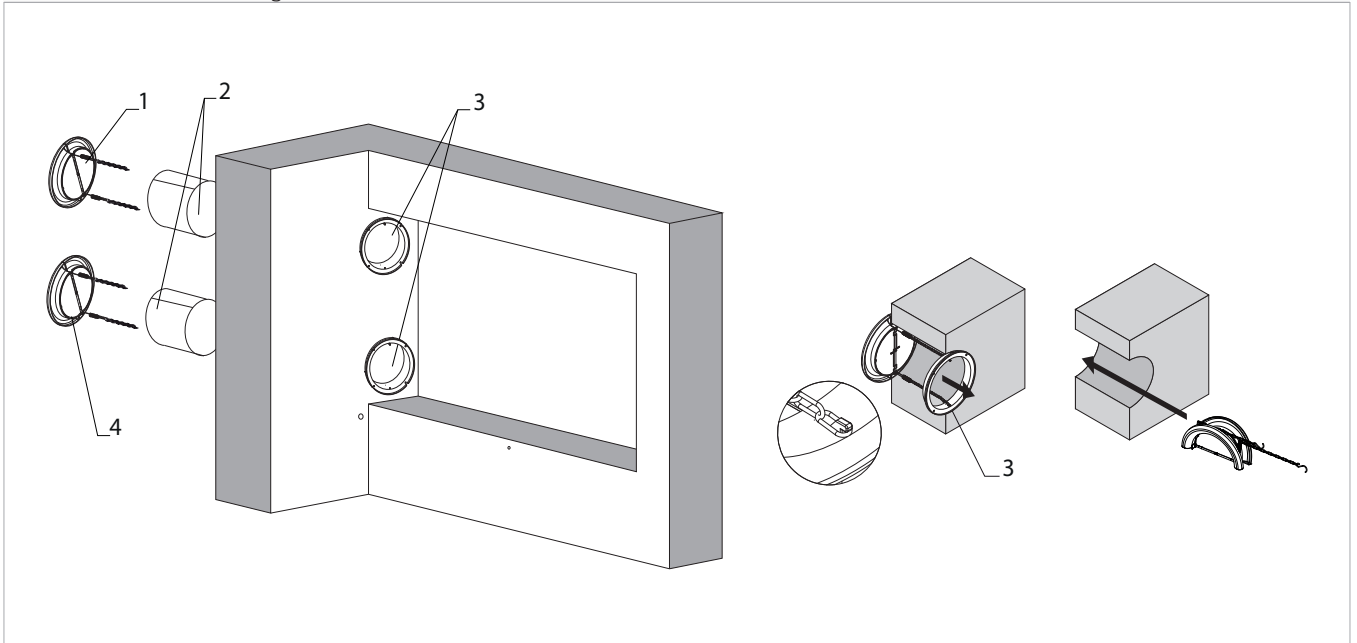

Box installation

- 1. Wall housing mould
- 2. External perimeter wall
- 3. Fixing bracket 2.0
- 4. Lateral ventilation box
- 5. Cable for electrical connection

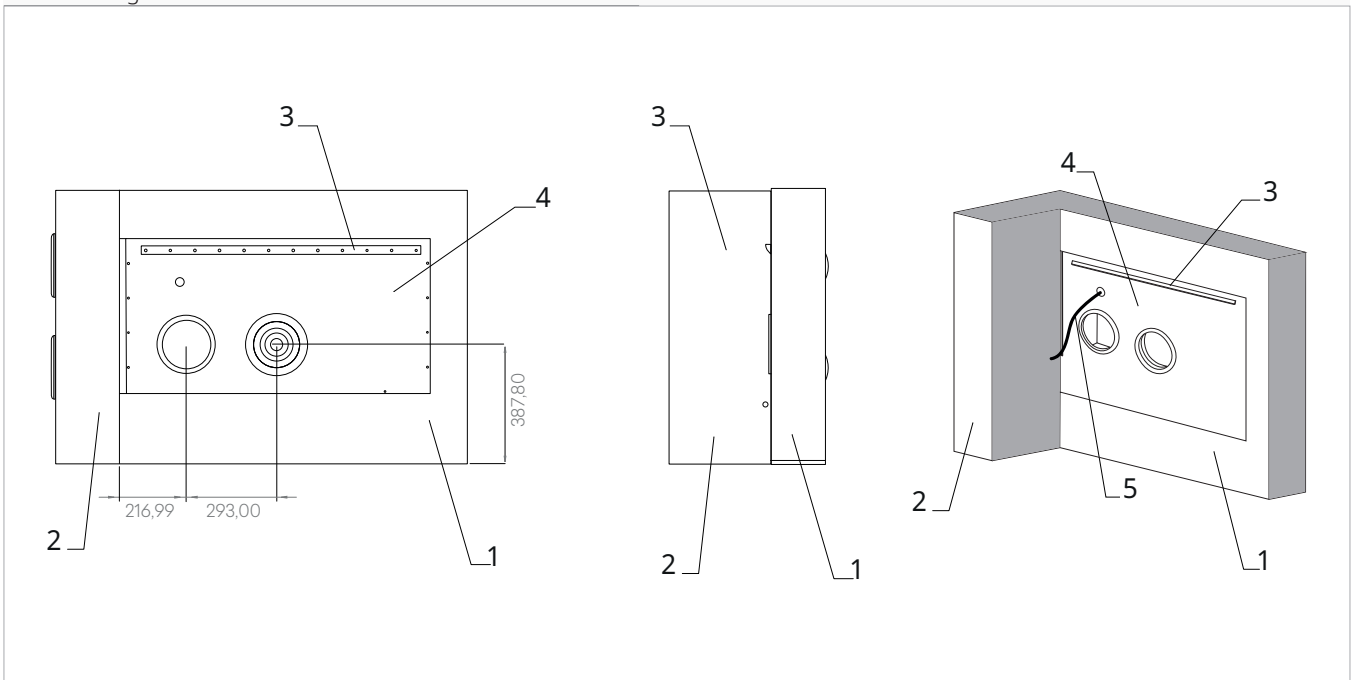

To install the metal casing:

► Insert the fromwork completely into the space provided

► Fix into the wall properly the fromwork

Unit installation

⚠ Before installing the unit on the bracket, run the cables coming out of the mould through the left shoulder of the unit.

⚠ For the installation of the appliance, refer to its installation manual.

1. Mould connection cable
2. Access to electric connections

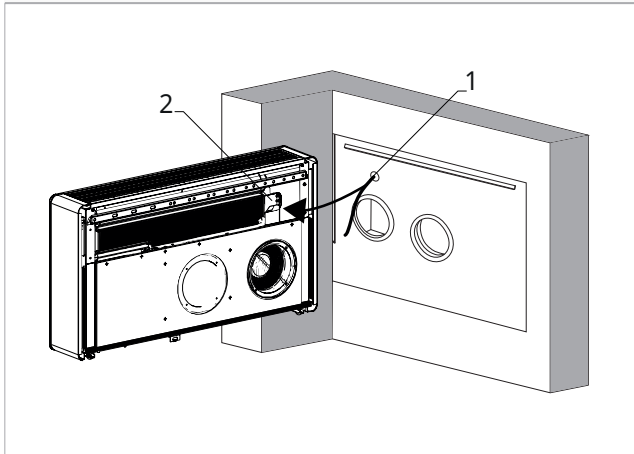

► run the cables through the left shoulder of the device

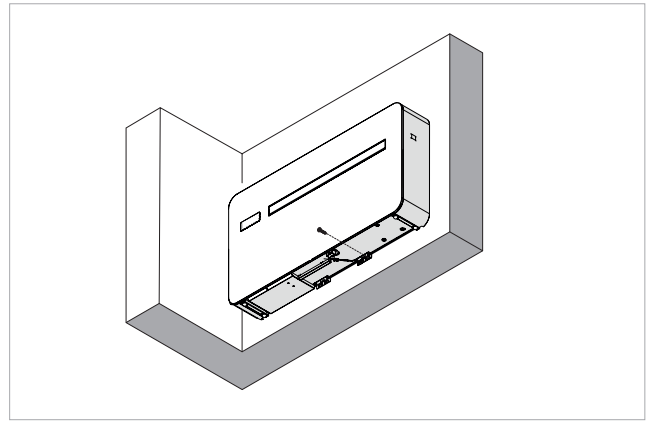

► anchor the unit to the wall using the anti-lift bracket located at the bottom of the unit

1. Liquid drain pipe

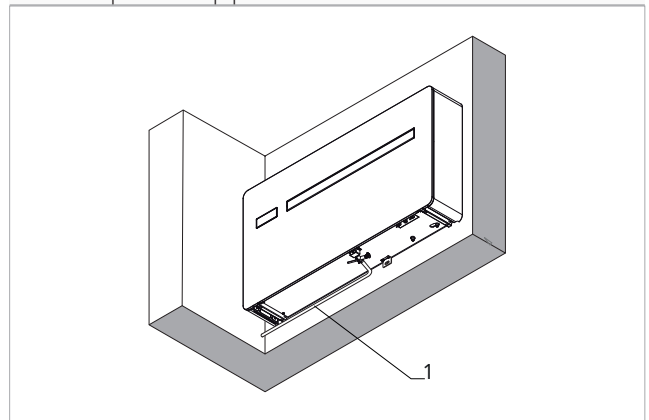

► connect the liquid drain pipe.

Electric connections

Refer to the manual of the appliance on which the kit is installed to access the electrical connections section.

- ⚠ To make electrical connections:
- check that the mould power cables have been correctly routed through the left shoulder of the unit
 - use the cable supplied with the formwork (part no. N500172B)

- | | | | |
|----|---|----|---|
| 1. | PCB | 6. | 4-wire, male JST terminal of the wiring harness |
| 2. | Contact J15 fan output | 7. | Wiring N500172B |
| 3. | Mould connection cable | 8. | 5-wire, female JST connector of the mould |
| 4. | 5-wire, male JST terminal of the wiring harness | 9. | JST 5-wire, female fan connector |

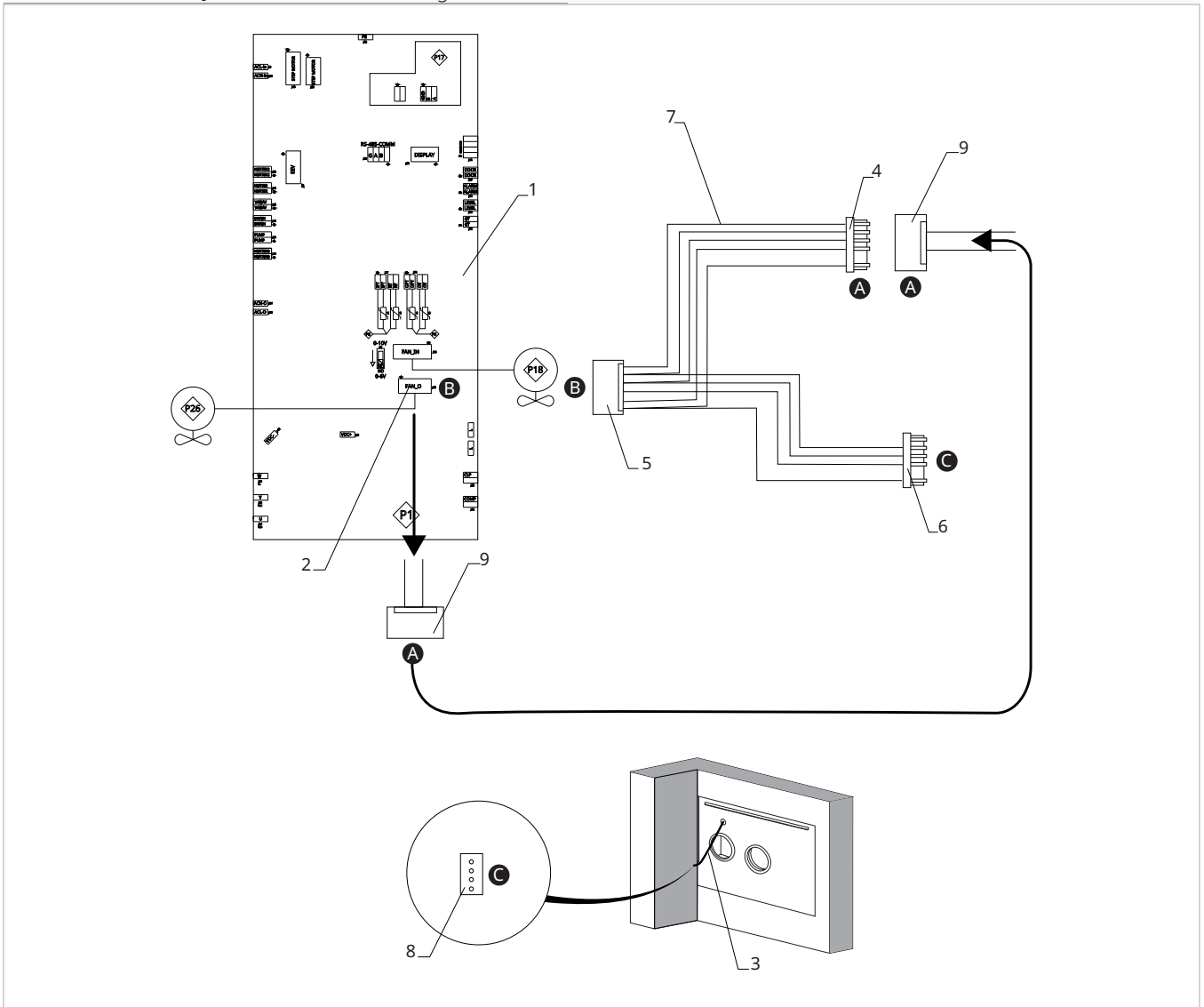

To make the connections:

- ▶ disconnect the 5-wire, female JST connector of the fan (9) from the PCB (2)
- ▶ connect the 5-wire, female JST connector of the fan (9) to the 5-wire, male JST terminal of the wiring harness (4)
- ▶ connect the 5-wire, female JST connector of the wiring harness (5) to contact J15 (2)
- ▶ Connect the 4-wire, male JST terminal of the wiring harness (6) to the 5-wire, female JST connector of the mould (8)

⚠ For connections follow the pairing of the letters A-A, B-B, etc.

1.	Blue cable	4.	Black cable
2.	Yellow cable	5.	Red cable
3.	White cable		

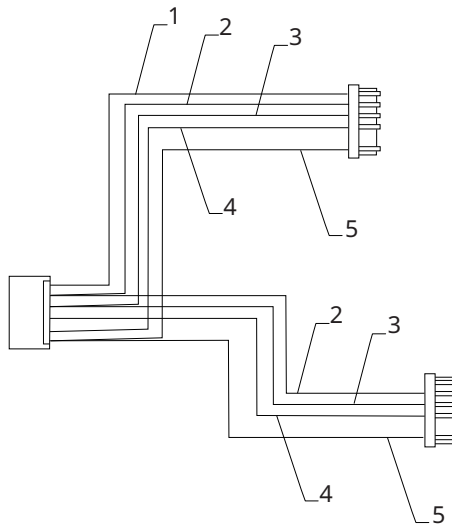

⚠ Please verify that the cable colours are correctly connected in sequence (blue, yellow, white, black and red) as shown in the picture.

⚠ If the connections are not correctly executed, please fix them before proceeding.